

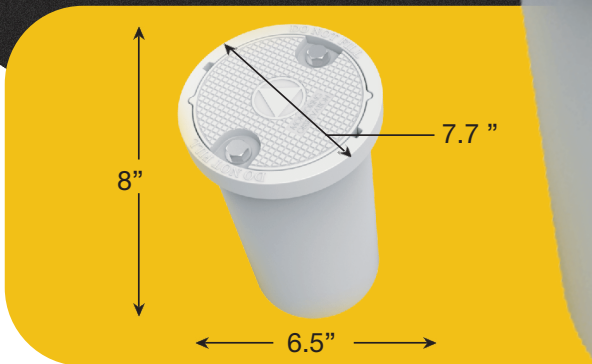

# ALUCAST



Product Number: 1020

## ALUCAST 6" MANHOLE COVER

► **The Best and Safest  
Monitoring Well  
Protection in the World**

### Product Specifications

- 6" x 8" Aluminum Manhole Cover
- 2 Bolts SS - Water Resistant
- Weight: 5.8 lbs
- 7.7" DIA. Aluminum Ring Frame
- 0.51" Thick Cover Plate
- 1/2" x 1/8" BUNA-N Gasket

### Distributors Worldwide

Alucast currently features distributors in:

- Canada
- United States
- Australia
- United Kingdom
- France
- Germany
- Mexico
- Spain

### Customizable Logo

#### Rep Your Site.

We now offer custom branding for all of our products. Your well protection can feature your company logo, website & choice of colour. Send us your logo and we'll provide a free rendering.

